

**basicDIM Wireless Sensor 5DP 38rc**

Casambi Ready wireless sensor

**Product description**

- Component of the basicDIM Wireless system (Casambi ready)
- Ambient light dependent control and presence detection
- Wireless controllable with an Android / iOS smart device
- Forms automatically a wireless communication network with up to 250 nodes
- Power supply via mains
- Mounting variants for suspended ceilings and solid ceilings available
- Passive Infrared sensor technology
- Shutters included to optimize sensor detection area
- 5 years guarantee

**Standards**, page 4



## basicDIM Wireless Sensor 5DP 38rc

Casambi Ready wireless sensor

### Technical data

Rated supply voltage	220 – 240 V
Mains frequency	50 / 60 Hz
Typ. input power	0.17 W
Max. input power	< 0.5 W
Typ. input power on stand-by	0.15 W
Mounting height	max. 4 m
Detection range, mounted at height of 3 m	ø 8 m
Detection angle	53°
Light measurement at sensor head	1 – 2,000 lx (± 20 %)
Radio transceiver operating frequencies	2.4 – 2.483 GHz
Max. output power radio transceiver (E.I.R.P.) <sup>①</sup>	< +20 dBm
Operating temperature	0 ... +50 °C
Storage temperature	-40 ... +85 °C
Type of protection	IP20

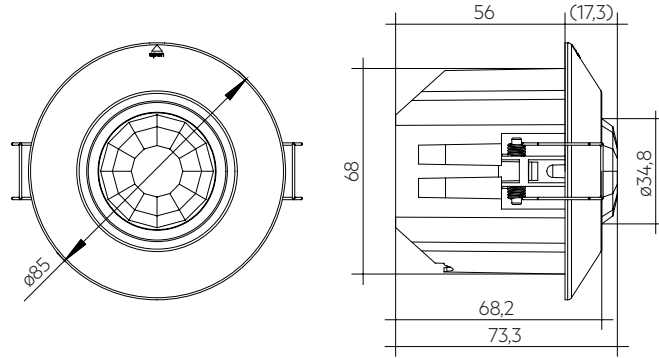

### Ordering data

Type	Article number	Dimensions L x W x H	Packaging, carton	Weight per pc.
basicDIM Wireless Sensor 5DP 38rc	28002801	85.0 x 85.0 x 73.3 mm	24 pc(s).	0.090 kg

① E.I.R.P.: Equivalent Isotropically Radiated Power.

## Sensor housing bDW rs

**Product description**

- Housing accessory for installations with solid ceiling
- Quick and easy installation
- Optimized mechanical concept to fix the basicDIM Wireless sensor with the accessory housing (patent pending)
- Release of the sensor from the housing can easily be done with a screwdriver or pen

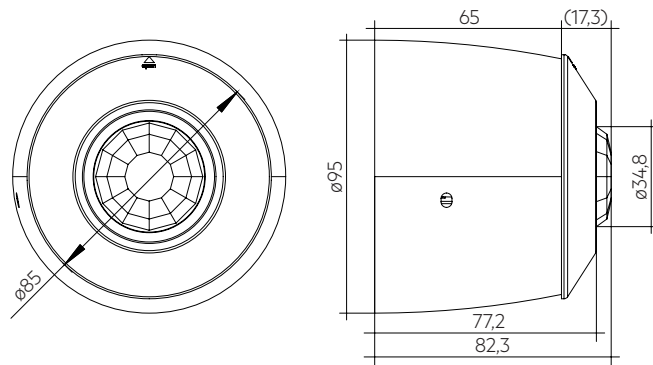
**Ordering data**

Type	Article number	Packaging, carton	Weight per pc.
Sensor housing bDW rs	28002802	18 pc(s).	0.055 kg

## 1. Standards

EN 60669-1, EN 60669-2-1  
 EN 55015  
 EN 61547  
 EN 61000-3-2  
 EN 61000-3-3  
 EN 300 328  
 EN 301 489-1  
 EN 301 489-17  
 EN 62479  
 EN 62493  
 AS/NZS 4268  
 FCC complied: FCC/VOC: Part 15 C, FCC-ID: 2AMXZ-0004  
 UL Standard: UL773A

This device complies with Part 15 of the FCC Rules. Operation is subject to the following two conditions:

- (1) this device may not cause harmful interference, and
- (2) this device must accept any interference received, including interference that may cause undesired operation.

### 1.1 Glow wire test

according to EN 61347-2-11 with increased temperature of 750 °C passed.

## 2. Common

### 2.1 Description

The basicDIM Wireless Sensor 5DP 38rc is the ideal addition to the basicDIM Wireless series of products as it offers daylight-dependent lighting control and presence detection.

It has been designed for the following principal applications:

- Individual offices
- Open-plan offices
- Training / presentation rooms
- Corridors, passageways and garages

The basicDIM Wireless Sensor 5DP 38rc supports presence detection and daylight control and is designed that it can be used together with basicDIM Wireless components (e.g. basicDIM Wireless Module).

The basicDIM Wireless Sensor 5DP 38rc is fully compatible with networks which support up to 250 nodes (Evolution networks). If the sensor is used with different types of basicDIM Wireless devices in an Evolution network, their compatibility has to be checked before. If a device is not compatible with Evolution networks, it can be only used in networks which support up to max. of 127 devices (Classic networks).

basicDIM Wireless devices are controlled and configured wirelessly by a smartphone or tablet with 4remote BT-App. Devices form automatically a secure wireless mesh network so that a large number of fixtures can be controlled from any point. No external gateway module is needed.

The settings and modes can be configured using the 4remote BT-App available in the App Store and Google Play Store. Made configurations are automatically stored in the Tridonic cloud service. This way the same settings are available for everyone who is connected to the network. For further information please refer to the 4remote BT-App – Product documentation on: [www.tridonic.com](http://www.tridonic.com).

## 3. Thermal details and lifetime

### 3.1 Expected lifetime

Expected lifetime		
Type	ta	50 °C
basicDIM Wireless Sensor 5DP 38rc	Lifetime	100,000 h

The device is designed for a lifetime stated above under reference conditions and with a failure probability of less than 10 %.

## 4. Installation / wiring

### 4.1 Combinations

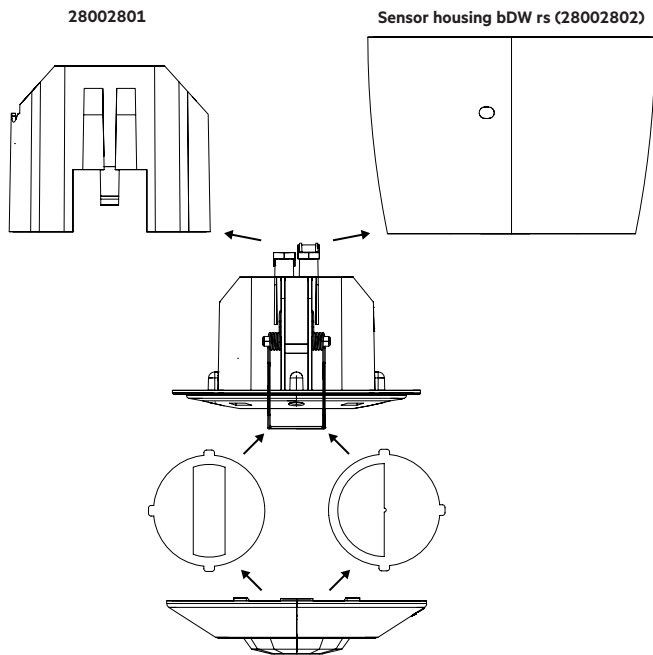

### 4.2 Mounting possibilities strain relief

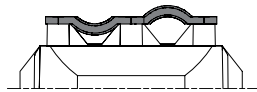

### 4.3 Installation rear cover (28002801)

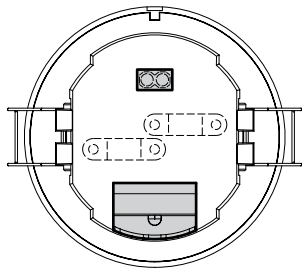

**!** When using the supplied rear cover of the sensor, make sure that it is installed correctly. It must be mounted so that the cable cutout is on the opposite side of the connection clamp.

### 4.4 Wiring diagram

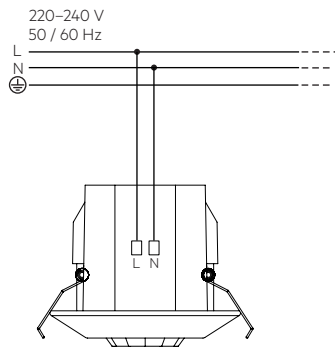

### 4.5 Wiring type and cross section

The wiring can be in stranded wires with ferrules or solid with a cross section of 0.75 – 2.5 mm<sup>2</sup> (20–14 AWG).

Strip 8 mm of insulation from the cables to ensure perfect operation of the push-wire terminals.

Use one wire for each terminal connector only.

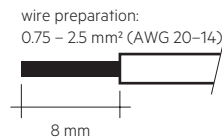

### 4.6 Placement



The range of the communication signal is depending on the environment e.g. luminaire, construction of the building, furnitures or humans and needs to be tested and approved in the installation.



To ensure a good radio connection, do not cover the basicDIM Wireless Sensor completely with metal!

### 4.7 Installation note

Max. torque at the clamping screw: 0.4 Nm / M3.



When you use the RS housing push back the springs of the sensor. Insert the sensor into the RS housing and turn him clockwise until you hear it snap.

To uninstall him, push a flat head screw driver (size 1) into the hole of the side of the RS housing to unlock the spring and turn him counterclockwise. You can then remove the sensor from the RS housing.

**ATTENTION:** The retaining springs can spring back when the sensor is removed, which can lead to injuries. So be careful when handling the sensor.

- The power supply must be disconnected before installation.
- Avoid direct illumination of the light source on the sensor including housing.
- Heaters, fans, printers and copiers located in the detection zone may cause incorrect presence detection.
- To avoid false readings, the sensor should be installed so there is no direct light from the lamp in the detection zone.
- Make sure that the basicDIM Wireless Sensor is not surrounded by metal. This can significantly reduce the wireless range of the sensor.
- When installed at a height other than the recommended installation height, the presence sensor might show different characteristics. When mounted at a higher level, its sensitivity is reduced.
- When using the supplied rear cover of the sensor, make sure that it is installed correctly. It must be mounted so that the cable cutout is on the opposite side of the connection clamp.

## 5. Sensor functions

### 5.1 Presence / motion detection

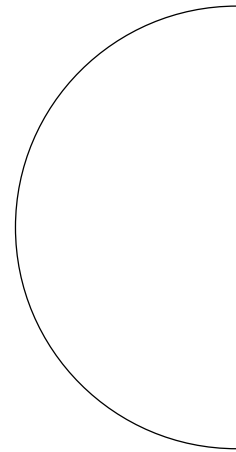
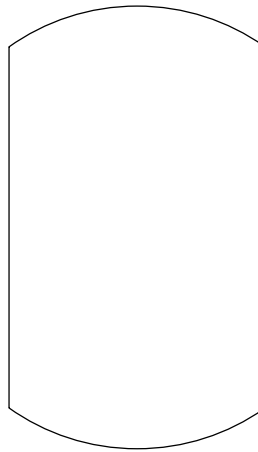
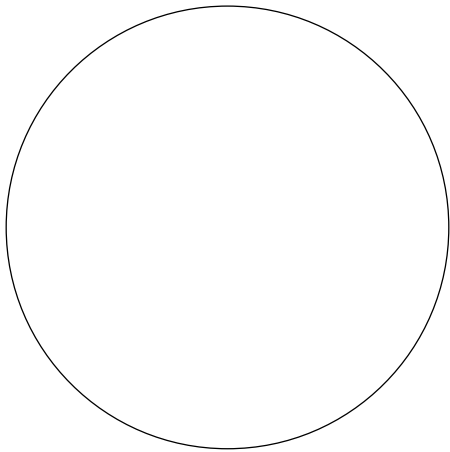
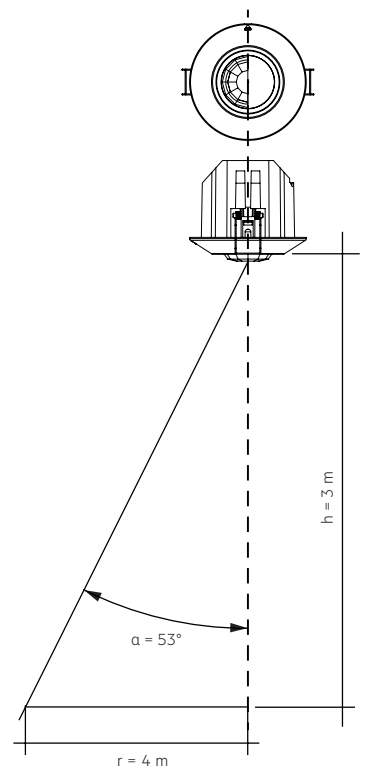
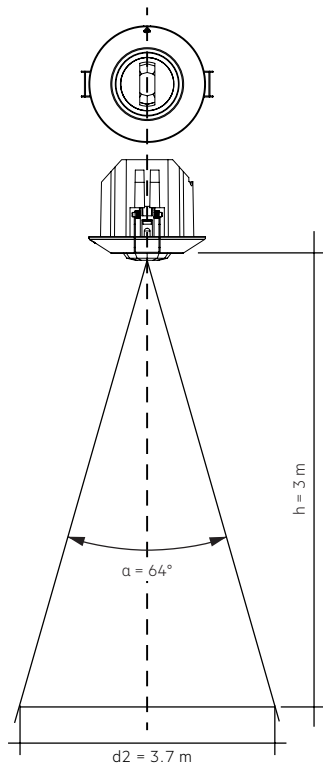
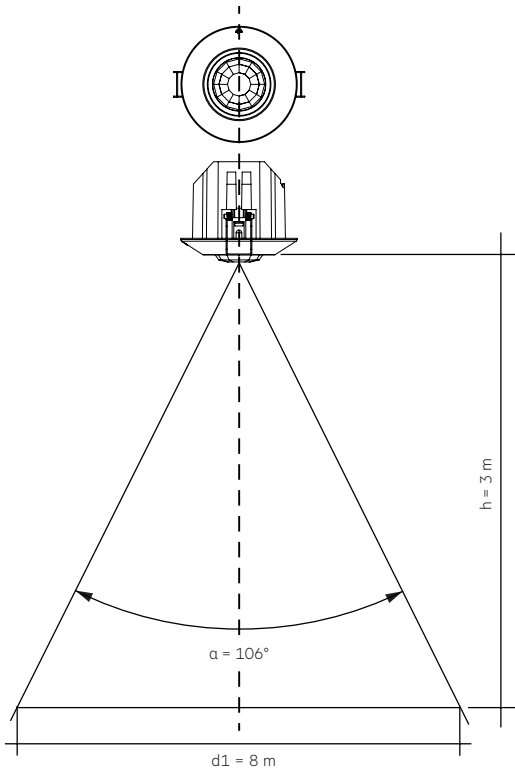

h	d1	d2	r
2.0 m	5.3 m	2.5 m	2.7 m
2.5 m	6.6 m	3.1 m	3.3 m
3.0 m	8.0 m	3.7 m	4.0 m
3.5 m	9.3 m	4.4 m	4.6 m
4.0 m	10.6 m	5.0 m	5.3 m

## 5.2 Light level recognition area

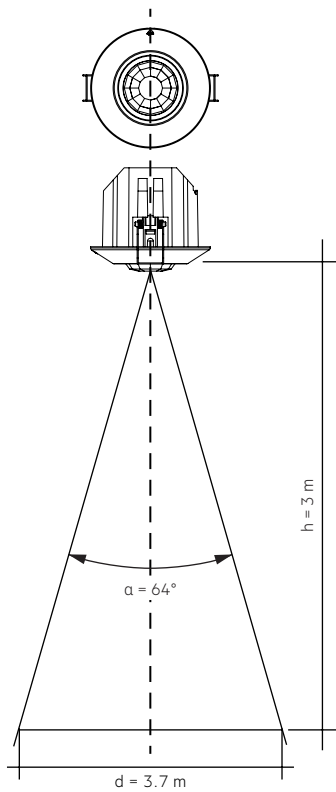

h	d
2.0 m	2.5 m
2.5 m	3.1 m
3.0 m	3.7 m
3.5 m	4.4 m
4.0 m	5.0 m

## 6. Miscellaneous

### 6.1 Disposal of equipment



Return old devices in accordance with the WEEE directive to suitable recycling facilities.

### 6.2 Conditions of use and storage

Environmental conditions: 5% up to max. 95%,  
not condensed

Storage temperature: -40 °C up to max. +80 °C

The devices have to be acclimatised to the specified temperature range ( $t_a$ ) before they can be operated.

### 6.3 Additional information

The Bluetooth® word mark and logos are registered trademarks owned by the Bluetooth SIG, Inc. and any use of such marks by Zumtobel Group AG is under license.

Tridonic GmbH & Co. KG is a subsidiary of Zumtobel Group AG.

Additional technical information at [www.tridonic.com](http://www.tridonic.com) → Technical Data

Guarantee conditions at [www.tridonic.com](http://www.tridonic.com) → Services

Lifetime declarations are informative and represent no warranty claim.  
No warranty if device was opened.